

This chapter explains how to install the Cisco ONS 15454 SDH cards and fiber-optic cable (fiber).

Contents

- [1 Before You Begin](#)
- [2 NTP-D15 Install the Common Control Cards](#)
 - ◆ [2.1 Figure 2-1: Installing Cards in the ONS 15454 SDH](#)
 - ◆ [2.2 Table 2-1: ONS 15454 SDH Card and Slot Compatibility for the XC-VXL-2.5G Cards](#)
 - ◆ [2.3 Table 2-2: Slot Compatibility for the XC-VXL-10G or XC-VXC-10G Card](#)
- [3 NTP-D16 Install STM-N Cards and Connectors](#)
 - ◆ [3.1 Table 2-3: Maximum Bandwidth by Shelf Slot for the MRC-12 in Different Cross-Connect Configurations](#)
- [4 NTP-D17 Install the Electrical Cards](#)
- [5 NTP-D18 Install Ethernet Cards and Connectors](#)
- [6 NTP-D286 Install the FC MR-4 Cards](#)
- [7 NTP-D348 Install the Filler Cards](#)
- [8 NTP-D349 Install the Blank Faceplates](#)
- [9 NTP-D19 Install Fiber-Optic Cables on Optical Cards](#)
 - ◆ [9.1 Table 2-4: Optical Card Transmit and Receive Levels](#)
- [10 NTP-D245 Route Fiber-Optic Cables](#)
 - ◆ [10.1 Figure 2-2: Fold-Down Front Door of the Cable-Management Tray](#)
 - ◆ [10.2 Figure 2-3: Routing Fiber-Optic Cables on the Optical-Card Faceplate](#)
- [11 NTP-D227 Remove and Replace a Card](#)
- [12 NTP-D20 Replace the Front Door](#)
 - ◆ [12.1 Figure 2-4: ONS 15454 SDH Front Door with Hinges and Ground Wire](#)

Before You Begin

This section lists the chapter procedures (NTPs). Turn to a procedure for applicable tasks (DLPs).

1. [NTP-D15 Install the Common Control Cards](#)-Complete this procedure before installing any other cards.
2. [NTP-D16 Install STM-N Cards and Connectors](#)-Complete this procedure as needed.
3. [NTP-D17 Install the Electrical Cards](#)-Complete this procedure as needed.
4. [NTP-D18 Install Ethernet Cards and Connectors](#)-Complete this procedure as needed.
5. [NTP-D286 Install the FC MR-4 Cards](#)-Complete this procedure as needed.
6. [NTP-D348 Install the Filler Cards](#)-Complete this procedure as needed.
7. [NTP-D349 Install the Blank Faceplates](#)-Complete this procedure as needed.
8. [NTP-D19 Install Fiber-Optic Cables on Optical Cards](#)-Complete this procedure as needed.
9. [NTP-D245 Route Fiber-Optic Cables](#)-Complete this procedure as needed.
10. [NTP-D227 Remove and Replace a Card](#)-Complete this procedure as needed to remove and replace a card, including deleting the card from Cisco Transport Controller (CTC) and changing an optical card without losing the card's provisioning.
11. [NTP-D20 Replace the Front Door](#)-If the front door was removed, complete this procedure to replace the front door and ground strap after installing cards and fiber.

Warning! Only trained and qualified personnel should be allowed to install, replace, or service this equipment. Statement 1030

Warning! Filler cards serve three important functions: they prevent exposure to hazardous voltages and currents inside the chassis; they contain electromagnetic interference (EMI) that might disrupt other equipment; and they direct the flow of cooling air through the chassis. Do not operate the system unless all cards and faceplates are in place. Statement 156

NTP-D15 Install the Common Control Cards

Purpose	This procedure describes how to install the common control cards.
Tools/Equipment	Redundant TCC2/TCC2P cards Redundant XC-VXL-2.5G, XC-VXL-10G, or XC-VXC-10G cross-connect cards AIC-I card (optional)
Prerequisite Procedures	<u>NTP-D13 Perform the Shelf Installation Acceptance Test</u>
Required/As Needed	Required
Onsite/Remote	Onsite
Security Level	Provisioning or higher

Warning! During this procedure, wear grounding wrist straps to avoid ESD damage to the card. Do not directly touch the backplane with your hand or any metal tool, or you could shock yourself.
Statement 94

Caution! Always use the supplied ESD wristband when working with a powered ONS 15454 SDH. Plug the wristband cable into the ESD jack located on the lower-right outside to edge of the shelf assembly.

Note: If protective clips are installed on the backplane connectors of the cards, remove the clips before installing the cards.

Note: If you install a card incorrectly, the FAIL LED flashes continuously.

1. If you plan to install XC-VXL-2.5G cards, review Table 2-1 to determine card/slot compatibility. If you plan to install XC-VXL-10G or XC-VXC-10G cards, review Table 2-2 to determine card/slot compatibility.
2. Complete the "DLP-D332 Install the TCC2/TCC2P Cards" task.

Figure 2-1 shows card installation.

Figure 2-1: Installing Cards in the ONS 15454 SDH

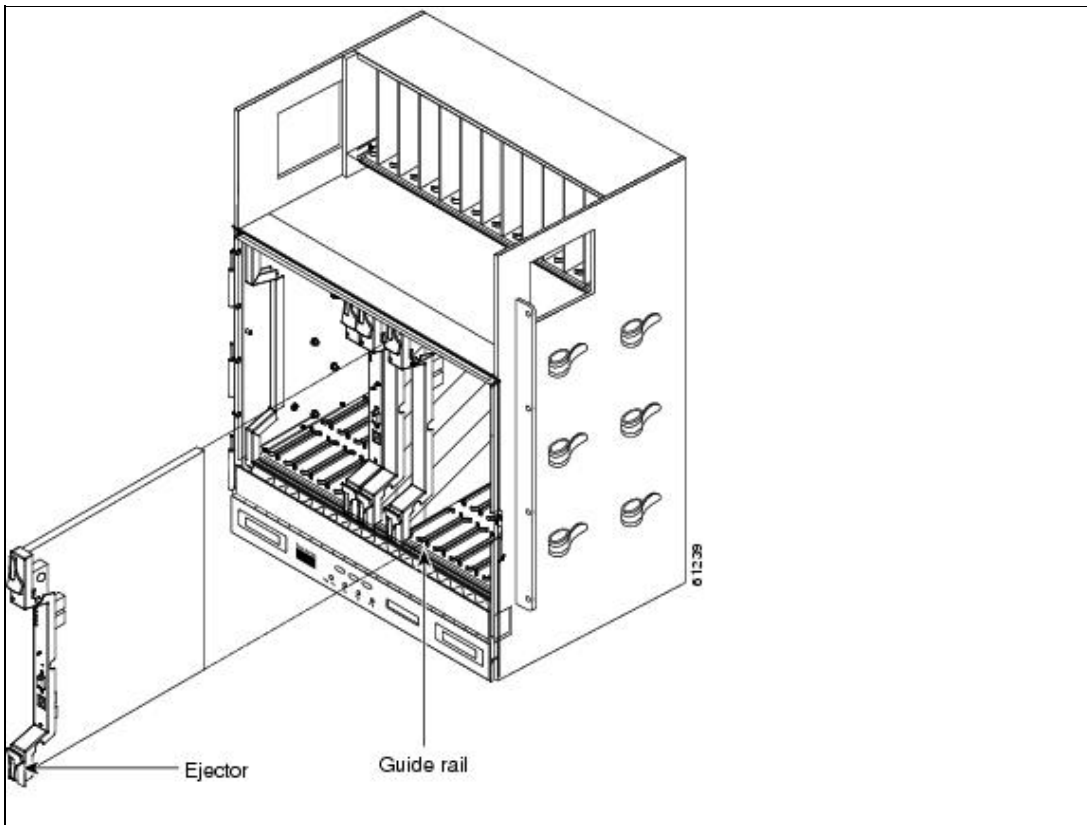

3. Complete the "DLP-D333 Install the XC-VXL-10G, XC-VXL-2.5G, or XC-VXC-10G Cards" task.

Note: If you install the wrong card in a slot, see the NTP-D227 Remove and Replace a Card.

4. Complete the "DLP-D334 Install the Alarm Interface Controller-International Card" task, if necessary.

In Table 2-1, X indicates that a card is supported in the slot. The multiservice (traffic) slots, Slots 1 to 6 and 12 to 17, include four slots (Slots 5, 6, 12, and 13) that have four times the bandwidth of the other multiservice slots.

Table 2-1: ONS 15454 SDH Card and Slot Compatibility for the XC-VXL-2.5G Cards

Slot	1	2	3	4	5	6	7	8	9	10	11	12	13	14	15	16	17
Type	MS	MS	MS	MS	MS	MS	TCC2/ TCC2P	XC ¹	AIC-I	XC ¹	TCC2/ TCC2P	MS	MS	MS	MS	MS	MS
TCC2/TCC2P							X				X						
XC-VXL-2.5G								X		X							
AIC-I									X								
DS3i-N-12	X	X	X	X	X								X	X	X	X	X
E1-42	X	X	X	X										X	X	X	X
E3-12	X	X	X	X	X								X	X	X	X	X
STM1E-12	X	X	X	X										X	X	X	X
E100T-G	X	X	X	X	X	X						X	X	X	X	X	X
E1000-2-G	X	X	X	X	X	X						X	X	X	X	X	X
G1000-4	X	X	X	X	X	X						X	X	X	X	X	X
G1K-4	X	X	X	X	X	X						X	X	X	X	X	X

Figure 2-1: Installing Cards in the ONS 15454 SDH

ONS_15454_SDH_Procedure_Guide_R8.5.1_--_Install_Cards_and_Fiber-Optic_Cable

ML100T-12	X	X	X	X	X	X						X	X	X	X	X	X
ML1000-2	X	X	X	X	X	X						X	X	X	X	X	X
ML-MR-10	X	X	X	X	X	X						X	X	X	X	X	X
CE-MR-10	X	X	X	X	X	X						X	X	X	X	X	X
CE-100T-8	X	X	X	X	X	X						X	X	X	X	X	X
CE-1000-4	X	X	X	X	X	X						X	X	X	X	X	X
OC3 IR 4/STM1 SH 1310	X	X	X	X	X	X						X	X	X	X	X	X
OC3IR/STM1 SH 1310-8	X	X	X	X										X	X	X	X
OC12 IR/STM4 SH 1310	X	X	X	X	X	X						X	X	X	X	X	X
OC12 LR/STM4 LH 1310	X	X	X	X	X	X						X	X	X	X	X	X
OC12 LR/STM4 LH 1550	X	X	X	X	X	X						X	X	X	X	X	X
OC12 LR/STM4 LH 1310-4	X	X	X	X										X	X	X	X
OC12 LR/STM4 LH 1550	X	X	X	X	X	X						X	X	X	X	X	X
OC48 IR/STM16 SH AS 1310	X	X	X	X	X	X						X	X	X	X	X	X
OC48 LR/STM16 LH AS 1550	X	X	X	X	X	X						X	X	X	X	X	X
OC48 ELR/STM16 EH 100 GHz					X	X						X	X				
OC192 SR/STM64 IO 1310	Not supported with XC-VXL-2.5G cards. Requires XC-VXL-10G or XC-VXC-10G cards.																
OC192 IR/STM64 SH 1550	Not supported with XC-VXL-2.5G cards. Requires XC-VXL-10G or XC-VXC-10G cards.																
OC192 LR/STM64 LH 1550	Not supported with XC-VXL-2.5G cards. Requires XC-VXL-10G or XC-VXC-10G cards.																
OC192 LR/STM64 LH ITU 15xx.xx	Not supported with XC-VXL-2.5G cards. Requires XC-VXL-10G or XC-VXC-10G cards.																
FC_MR-4	X	X	X	X	X	X						X	X	X	X	X	X
15454_MRC-12 ²	Not supported with XC-VXL-2.5G cards. Requires XC-VXL-10G or XC-VXC-10G cards.																
OC192SR1/STM64IO Short Reach and OC192/STM64 Any Reach ³	Not supported with XC-VXL-2.5G cards. Requires XC-VXL-10G or XC-VXC-10G cards.																

1. The term XC is used generically to mean cross-connect card.

ONS_15454_SDH_Procedure_Guide_R8.5.1_--_Install_Cards_and_Fiber-Optic_Cable

2. Designated as MRC-12 in CTC.

3. Designated as STM64-XFP in CTC

In Table 2-2, X indicates that a card is supported in the slot. The multiservice (traffic) slots, Slots 1 to 6 and 12 to 17, include four slots (Slots 5, 6, 12, and 13) that have four times the bandwidth of the other multiservice slots.

Table 2-2: Slot Compatibility for the XC-VXL-10G or XC-VXC-10G Card

Slot	1	2	3	4	5	6	7	8	9	10	11	12	13	14	15	16	17
Type	MS	MS	MS	MS	MS	MS	TCC2/TCC2P	XC ¹	AIC-I	XC ¹	TCC2/TCC2P	MS	MS	MS	MS	MS	MS
TCC2/TCC2P							X				X						
XC-VXL-10G								X		X							
XC-VXC-10G								X		X							
AIC-I									X								
DS3i-N-12	X	X	X	X	X								X	X	X	X	X
E1-42	X	X	X	X										X	X	X	X
E3-12	X	X	X	X	X								X	X	X	X	X
STM1E-12	X	X	X	X										X	X	X	X
E100T-G	X	X	X	X	X	X						X	X	X	X	X	X
E1000-2-G	X	X	X	X	X	X						X	X	X	X	X	X
G1000-4	X	X	X	X	X	X						X	X	X	X	X	X
G1K-4	X	X	X	X	X	X						X	X	X	X	X	X
ML100T-12	X	X	X	X	X	X						X	X	X	X	X	X
ML1000-2	X	X	X	X	X	X						X	X	X	X	X	X
ML-MR-10	X	X	X	X	X	X						X	X	X	X	X	X
CE-MR-10	X	X	X	X	X	X						X	X	X	X	X	X
CE-100T-8	X	X	X	X	X	X						X	X	X	X	X	X
CE-1000-4	X	X	X	X	X	X						X	X	X	X	X	X
OC3 IR 4/STM1 SH 1310	X	X	X	X	X	X						X	X	X	X	X	X
OC3IR/STM1SH 1310-8	X	X	X	X										X	X	X	X
OC12 IR/STM4 SH 1310	X	X	X	X	X	X						X	X	X	X	X	X
OC12 LR/STM4 LH 1310	X	X	X	X	X	X						X	X	X	X	X	X
OC12 LR/STM4 LH 1550	X	X	X	X	X	X						X	X	X	X	X	X
OC12 LR/STM4 LH 1310-4	X	X	X	X										X	X	X	X
OC12 LR/STM4 LH 1550	X	X	X	X	X	X						X	X	X	X	X	X
OC48 IR/STM16 SH AS 1310	X	X	X	X	X	X						X	X	X	X	X	X
OC48 LR/STM16 LH	X	X	X	X	X	X						X	X	X	X	X	X

Table 2-2: Slot Compatibility for the XC-VXL-10G or XC-VXC-10G Card

AS 1550																	
OC48 ELR/STM16 EH 100 GHz	X	X	X	X	X	X							X	X	X	X	X
OC192 SR/STM64 IO 1310					X	X							X	X			
OC192 IR/STM64 SH 1550					X	X							X	X			
OC192 LR/STM64 LH 1550					X	X							X	X			
OC192 LR/STM64 LH ITU 15xx.xx					X	X							X	X			
OC192SR1/ STM64IO Short Reach and OC192/STM64 Any Reach ²					X	X							X	X			
FC_MR-4	X	X	X	X	X	X							X	X	X	X	X
15454_MRC-12 ³	X	X	X	X	X	X							X	X	X	X	X

1. The term XC is used generically to mean cross-connect card.

2. Designated as STM64-XFP in CTC.

3. Designated as MRC-12 in CTC

5. Continue with the following procedures, as needed:

- ◇ [NTP-D16 Install STM-N Cards and Connectors](#)
- ◇ [NTP-D17 Install the Electrical Cards](#)
- ◇ [NTP-D18 Install Ethernet Cards and Connectors](#)
- ◇ [NTP-D286 Install the FC MR-4 Cards](#)

Stop. You have completed this procedure.

NTP-D16 Install STM-N Cards and Connectors

Purpose	This procedure installs the optical cards (STM-1, STM1-8, STM-4, STM4-4, STM-16, STM-64, and 15454_MRC-12). The MRC-12 (multirate), OC192SR1/STM64IO Short Reach (STM64-XFP Short Reach), and OC192/STM64 Any Reach(STM64-XFP Any Reach) cards require Small Form-factor Pluggables (SFPs/XFPs) to provide the fiber interface to the cards. On all other optical cards, the fiber is plugged directly into the card. Install according to site plan, if available.
Tools/Equipment	STM-1, STM-4, STM-16, STM-64, and MRC-12 cards (as applicable)
Prerequisite Procedures	NTP-D15 Install the Common Control Cards
Required/As Needed	As needed

Onsite/Remote	Onsite
Security Level	None

Warning! During this procedure, wear grounding wrist straps to avoid ESD damage to the card. Do not directly touch the backplane with your hand or any metal tool, or you could shock yourself. Statement 94

Warning! Class I (21 CFR 1040.10 and 1040.11) and Class 1M (IEC 60825-1 2001-01) laser products. Statement 291

Warning! Invisible laser radiation may be emitted from the end of the unterminated fiber cable or connector. Do not view directly with optical instruments. Viewing the laser output with certain optical instruments (for example, eye loupes, magnifiers, and microscopes) within a distance of 100 mm may pose an eye hazard. Statement 1056

The following laser activation warning applies only to STM-64 cards with safety keys:

Warning! The laser is on when the card is booted and the safety key is in the on position (labeled 1). The port does not have to be in service for the laser to be on. The laser is off when the safety key is off (labeled 0). Statement 293

Caution! Always use the supplied ESD wristband when working with a powered ONS 15454 SDH. Plug the wristband cable into the ESD jack located on the lower-right outside edge of the shelf assembly.

Note: To simplify subnetwork connection protection (SNCP) to multiplex section-shared protection ring (MS-SPRing) conversion and node addition, install optical cards according to an east (Slots 12 and 13) to west (Slots 5 and 6) configuration. This configuration is not mandatory.

Note: If you install a card incorrectly, the FAIL LED flashes continuously.

Note: During the boot process, a Locked-enabled, disabled STM-N port will output a line alarm indication signal (AIS-L) to any Unlocked-enabled far-end receivers. See the *Cisco ONS 15454 SDH Troubleshooting Guide* for further information about the AIS-L condition.

1. If you installed XC-VXL-2.5G cards, review [Table 2-1](#) to determine card/slot compatibility. If you installed XC-VXL-10G or XC-VXC-10G cards, review [Table 2-2](#) to determine card/slot compatibility.

Install higher-capacity cards first; for example, install an STM-64 card before installing an STM-12 card. Let each card completely boot before installing the next card.

Note: "OC192SR1/STM64IO Short Reach" and "OC192/STM64 Any Reach" are the titles that appear on the faceplates of the STM64-XFP cards. In CTC, the cards are abbreviated as STM64-XFP.

Before installing a MRC-12 card, review [Table 2-3](#) for bandwidth limitations based on the slot where the card is installed and the type of cross-connect card installed in the shelf.

Table 2-3: Maximum Bandwidth by Shelf Slot for the MRC-12 in Different Cross-Connect Configurations

XC Card Type	Maximum Bandwidth in Slots 1 through 4 and 12 through 17	Maximum Bandwidth in Slots 5, 6, 12, or 13
XC-VXL-2.5G	OC-48	OC-48
XC-VXC-10G/XC-VXL-10G	OC-48	OC-192

Refer to the card's reference section in the "Optical Cards" chapter of the *Cisco ONS 15454 SDH Reference Manual* for more information about slot and bandwidth restrictions.

Table 2-3: Maximum Bandwidth by Shelf Slot for the MRC-12 in Different Cross-Connect Configurations

2. Open the card latches/ejectors.
3. Use the latches/ejectors to firmly slide the optical card along the guide rails until the card plugs into the receptacle at the back of the slot.
4. Verify that the card is inserted correctly and close the latches/ejectors on the card.

Note: It is possible to close the latches/ejectors when the card is not completely plugged into the backplane. Ensure that you cannot insert the card any further.

Note: If you install the wrong card in a slot, complete the [NTP-D227 Remove and Replace a Card](#).

5. Verify the LED activity:

- The red FAIL LED turns on for 20 to 30 seconds.
- The red FAIL LED blinks for 35 to 45 seconds.
- All LEDs blink once and turn off for 5 to 10 seconds.
- The ACT or ACT/STBY LED turns on. The signal fail (SF) LED can persist until all card ports connect to their far-end counterparts and a signal is present.

Note: The booting STM-N card will send an AIS-L to the far-end receiver as long as it is Locked-enabled, disabled.

6. If the card does not boot up properly, or the LED activity does not mimic Step 5, check the following:

- When a physical card type does not match the type of card provisioned for that slot in CTC, the card might not boot. If an optical card does not boot, open CTC and verify that the slot is not provisioned for a different card type before assuming the card is faulty.
- If the red FAIL LED does not turn on, check the power.
- If you insert a card into a slot provisioned for a different card, all LEDs turn off.
- If the red FAIL LED is illuminated continuously or the LEDs behave erratically, the card is not installed properly. Remove the card and repeat Steps 2 to 5.

7. The MRC-12 card requires SFPs and the STM64-XFP cards require XFPs to provide a fiber interface. If you installed any of these cards, complete the "[DLP-D335 Install GBIC or SFP/XFP Devices](#)" task or preprovision the SFP/XFP using the "[DLP-D107 Preprovision an SFP or XFP Device](#)" task.

8. Continue with the [NTP-D19 Install Fiber-Optic Cables on Optical Cards](#).

Stop. You have completed this procedure.

NTP-D17 Install the Electrical Cards

Purpose	This procedure installs the electrical cards (DS3i-N-12, E1-42, E3-12, and STM1E-12).
Tools/Equipment	Electrical cards
Prerequisite Procedures	NTP-D220 Install the Power and Signal FMECs NTP-D15 Install the Common Control Cards
Required/As Needed	As needed
Onsite/Remote	Onsite
Security Level	None

Warning! During this procedure, wear grounding wrist straps to avoid ESD damage to the card. Do not directly touch the backplane with your hand or any metal tool, or you could shock yourself.

Statement 94

Note: The E3-12 card can be deployed in a central office or a carrier's exchange.

Note: Install higher-capacity cards first; for example, install an E3-12 card before installing an E1-14 card. Let each card boot completely before installing the next card.

Note: Cisco recommends installing STM-N, transponder (TXP), and muxponder (MXP) cards before you install electrical cards, as applicable.

1. If you installed XC-VXL-2.5G cards, review [Table 2-1](#) to determine card/slot compatibility. If you installed XC-VXL-10G or XC-VXC-10G cards, review [Table 2-2](#) to determine card/slot compatibility.
2. Open the card latches/ejectors.
3. Use the latches/ejectors to firmly slide the card along the guide rails until the card plugs into the receptacle at the back of the slot.

Note: If you install the wrong card in a slot, complete the [NTP-D227 Remove and Replace a Card](#).

4. Verify that the card is inserted correctly and close the latches/ejectors on the card.

Note: It is possible to close the latches/ejectors when the card is not completely plugged into the backplane. Ensure that you cannot insert the card any further.

5. Verify the LED activity:

- ◆ The red FAIL LED turns on for 10 to 15 seconds.
- ◆ If the red FAIL LED does not turn on, check the power.
- ◆ The red FAIL LED blinks for 30 to 40 seconds.
- ◆ All LEDs blink once and turn off for 1 to 5 seconds.
- ◆ The ACT or ACT/STBY LED turns on. The SF LED can persist until all card ports connect to their far end counterparts and a signal is present.

Note: If you insert a card into a slot provisioned for a different card, all LEDs turn off.

Note: If the red FAIL LED is on continuously or the LEDs behave erratically, the card is not installed properly. Remove the card and repeat Steps 2 to 5.

6. Continue with the [NTP-D18 Install Ethernet Cards and Connectors](#) if necessary.

Stop. You have completed this procedure.

NTP-D18 Install Ethernet Cards and Connectors

Purpose	This procedure installs the Ethernet cards (E100T-G, E1000-2-G, G1K4, ML100T-12, ML1000-2, ML100X-8, ML-MR-10, CE-100T-8, CE-1000-4, and CE-MR-10).
Tools/Equipment	Ethernet cards
Prerequisite Procedures	NTP-D15 Install the Common Control Cards
Required/As Needed	As needed
Onsite/Remote	Onsite
Security Level	None

Warning! During this procedure, wear grounding wrist straps to avoid ESD damage to the card. Do not directly touch the backplane with your hand or any metal tool, or you could shock yourself.
Statement 94

Warning! Class I (21 CFR 1040.10 and 1040.11) and Class 1M (IEC 60825-1 2001-01) laser products. Statement 291

Warning! Invisible laser radiation may be emitted from the end of the unterminated fiber cable or connector. Do not view directly with optical instruments. Viewing the laser output with certain optical instruments (for example, eye loupes, magnifiers, and microscopes) within a distance of 100 mm may pose an eye hazard. Statement 1056

Warning! To comply with the Telcordia GR-1089 Network Equipment Building Systems (NEBS) standard for electromagnetic compatibility and safety, connect the copper Ethernet ports to intrabuilding or nonexposed wiring and cabling only.

Caution! Always use the supplied ESD wristband when working with a powered ONS 15454 SDH. Plug the wristband cable into the ESD jack located on the lower-right outside edge of the shelf assembly.

Note: Cisco recommends installing TXP, MXP, STM-N, and electrical cards before you install Ethernet cards, as applicable.

1. If you installed XC-VXL-2.5G cards, review [Table 2-1](#) to determine card/slot compatibility. If you installed XC-VXL-10G or XC-VXC-10G cards, review [Table 2-2](#) to determine card/slot compatibility.
2. Complete the "[DLP-D39 Install Ethernet Cards](#)" task. Allow each card to boot completely before installing the next card.
3. Complete the "[DLP-D335 Install GBIC or SFP/XFP Devices](#)" task if you are using E1000-2-G, G1K-4, ML1000-2, ML100X-8, ML-MR-10, CE-1000-4, or CE-MR-10 cards.
Note: If you need to remove a Gigabit Interface Converter (GBIC) or SFP/XFP, complete the "[DLP-D336 Remove GBIC or SFP/XFP Device](#)" task.
4. Continue with [NTP-D286 Install the FC_MR-4 Cards](#) if necessary.
Stop. You have completed this procedure.

NTP-D286 Install the FC_MR-4 Cards

Purpose	This procedure installs the FC_MR-4 card, also known as the Fibre Channel card.
Tools/Equipment	FC_MR-4 card(s)
Prerequisite Procedures	NTP-D15 Install the Common Control Cards
Required/As Needed	As needed
Onsite/Remote	Onsite
Security Level	None

Warning! During this procedure, wear grounding wrist straps to avoid ESD damage to the card. Do not directly touch the backplane with your hand or any metal tool, or you could shock yourself. Statement 94

Warning! Class I (21 CFR 1040.10 and 1040.11) and Class 1M (IEC 60825-1 2001-01) laser products. Statement 291

Warning! Invisible laser radiation may be emitted from the end of the unterminated fiber cable or connector. Do not view directly with optical instruments. Viewing the laser output with certain optical instruments (for example, eye loupes, magnifiers, and microscopes) within a distance of 100 mm may pose an eye hazard. Statement 1056

Caution! Always use the supplied ESD wristband when working with a powered ONS 15454 SDH. Plug the wristband cable into the ESD jack located on the lower-right outside edge of the shelf assembly.

Note: If protective clips are installed on the backplane connectors of the cards, remove the clips before installing the cards.

Warning! High-performance devices on this card can get hot during operation. To remove the card, hold it by the faceplate and bottom edge. Allow the card to cool before touching any other part of it or before placing it in an antistatic bag. Statement 201

1. If you installed XC-VXL-2.5G cards, review [Table 2-1](#) to determine card/slot compatibility. If you installed XC-VXL-10G or XC-VXC-10G cards, review [Table 2-2](#) to determine card/slot compatibility.
2. Open the card latches/ejectors.
3. Use the latches/ejectors to firmly slide the card along the guide rails until the card plugs into the receptacle at the back of the slot.
4. Verify that the card is inserted correctly and close the latches/ejectors on the card.
 - Note:** It is possible to close the latches/ejectors when the card is not completely plugged into the backplane. Ensure that you cannot insert the card any further.
 - Note:** If you install the wrong card in a slot, complete the [NTP-D227 Remove and Replace a Card](#) and install the correct card.
5. Verify the LED activity:
 - ◆ The red FAIL LED turns on for 20 to 30 seconds. The ACT LED is amber for 3 to 5 seconds.
 - ◆ The red FAIL LED blinks for up to 2 minutes.
 - ◆ The FAIL and ACT LEDs blink once and turn off for 1 to 5 seconds.
 - ◆ The ACT LED illuminates green.
 - Note:** If the red FAIL LED does not turn on, check the power.
 - Note:** If you insert a card into a slot provisioned for a different card, all LEDs turn off.
6. Complete the ["DLP-D335 Install GBIC or SFP/XFP Devices"](#) task to install GBICs on the FC_MR-4 card.
 - Note:** If you need to remove a GBIC or SFP/XFP, complete the ["DLP-D336 Remove GBIC or SFP/XFP Device"](#) task.
7. Continue with the [NTP-D19 Install Fiber-Optic Cables on Optical Cards](#).
 - Stop. You have completed this procedure.**

NTP-D348 Install the Filler Cards

Purpose	<p>This procedure explains how to install the filler cards in any unused traffic or AIC-I card slots (Slots 1 through 6, 9, and 12 through 17). A filler card consists of a card with a faceplate attached. There is no label on the faceplate and the filler card is not detectable by CTC.</p> <p>Filler cards aid in maintaining proper air flow and electromagnetic interference (EMI) requirements.</p>
Tools/Equipment	Filler cards (Cisco P/N 15454E-BLANK)
Prerequisite Procedures	<p>NTP-D15 Install the Common Control Cards</p> <p>NTP-D16 Install STM-N Cards and Connectors</p> <p>NTP-D17 Install the Electrical Cards</p>

	NTP-D18 Install Ethernet Cards and Connectors
	NTP-D286 Install the FC MR-4 Cards
Required/As Needed	As needed
Onsite/Remote	Onsite
Security Level	None

Warning! Filler cards serve three important functions: they prevent exposure to hazardous voltages and currents inside the chassis; they contain EMI that might disrupt other equipment; and they direct the flow of cooling air through the chassis. Do not operate the system unless all cards and faceplates are in place. Statement 156

Caution! Always use the supplied ESD wristband when working with a powered ONS 15454_SDH. Plug the wristband cable into the ESD jack located on the lower right outside edge of the shelf assembly and ensure the shelf assembly is properly grounded.

1. Open the card ejectors.
2. Slide the card along the guide rails into the correct slot.
3. Close the ejectors.
4. Repeat for any remaining unused card slots.

Stop. You have completed this procedure.

NTP-D349 Install the Blank Faceplates

Purpose	This procedure explains how to install the blank faceplates in any unused FMEC slot. A blank faceplate card is a sheet metal cover that is used to block any unused FMEC slot. The blank faceplate aids in maintaining proper air flow and EMI requirements.
Tools/Equipment	Screwdriver Blank faceplate cards (Cisco P/N 15454E-BLANK-FMEC)
Prerequisite Procedures	NTP-D15 Install the Common Control Cards NTP-D16 Install STM-N Cards and Connectors NTP-D17 Install the Electrical Cards NTP-D18 Install Ethernet Cards and Connectors NTP-D286 Install the FC MR-4 Cards NTP-D348 Install the Filler Cards
Required/As Needed	As needed
Onsite/Remote	Onsite
Security Level	None

Warning! Blank faceplates serve three important functions: they prevent exposure to hazardous voltages and currents inside the chassis; they contain EMI that might disrupt other equipment; and they direct the flow of cooling air through the chassis. Do not operate the system unless all cards and

faceplates are in place.

Caution! Always use the supplied ESD wristband when working with a powered ONS 15454_SDH. Plug the wristband cable into the ESD jack located on the lower right outside edge of the shelf assembly and ensure the shelf assembly is properly grounded.

1. With screws, attach the blank faceplate so that it covers the empty unused FMEC slot.
2. Repeat for any remaining unused FMEC slots.

Stop. You have completed this procedure.

NTP-D19 Install Fiber-Optic Cables on Optical Cards

Purpose	This procedure describes how to install fiber-optic cables on optical cards.
Tools/Equipment	Fiber-optic cables Fiber boot
Prerequisite Procedures	NTP-D16 Install STM-N Cards and Connectors
Required/As Needed	As needed
Onsite/Remote	Onsite
Security Level	None

Warning! Class I (21 CFR 1040.10 and 1040.11) and Class 1M (IEC 60825-1 2001-01) laser products. Statement 291

Warning! Invisible laser radiation may be emitted from the end of the unterminated fiber cable or connector. Do not view directly with optical instruments. Viewing the laser output with certain optical instruments (for example, eye loupes, magnifiers, and microscopes) within a distance of 100 mm may pose an eye hazard. Statement 1056

The following warning applies only to STM-64 cards with safety keys:

Warning! The laser is on when the card is booted and the safety key is in the on position (labeled 1). The port does not have to be in service for the laser to be on. The laser is off when the safety key is off (labeled 0). Statement 293

Caution! Do not use fiber loopbacks with the STM64 LH 1550 or STM64 LH ITU 15xx.xx card unless you are using a 20-dB attenuator. Never connect a direct fiber loopback. Using fiber loopbacks causes irreparable damage to the STM64 LH 1550 or STM64 LH ITU 15xx.xx card.

Caution! Do not use fiber loopbacks with the STM64 SH 1550 card unless you are using a 5-dB attenuator. Never connect a direct, unattenuated fiber loopback. Using unattenuated fiber loopbacks causes irreparable damage to the STM64 SH 1550 card.

Caution! Always use the supplied ESD wristband when working with a powered ONS 15454 SDH. Plug the wristband cable into the ESD jack located on the lower-right outside edge of the shelf assembly.

Note: You can install the fiber immediately after installing the cards, or wait until you are ready to turn up the network. See [Turn Up a Network](#).

Note: To install fiber-optic cables on Ethernet cards, FC_MR-4 cards, MRC-12 cards, or STM64-XFP cards, see the ["DLP-D335 Install GBIC or SFP/XFP Devices"](#) task.

ONS_15454_SDH_Procedure_Guide_R8.5.1_--_Install_Cards_and_Fiber-Optic_Cable

1. Test the optical receive levels for the cards installed and attenuate accordingly. [Table 2-4](#) provides the minimum and maximum levels.

Note: The levels for the 15454_MRC-12, OC192SR1/STM64IO Short Reach, and OC192/STM64 Any Reach (OC192-XFP) cards are dependent on the particular SFP/XFP installed in a port. The SFPs/XFPs are shown in parentheses in [Table 2-4](#) for these cards.

Table 2-4: Optical Card Transmit and Receive Levels

Card	Transmit		Receive	
	Minimum	Maximum	Minimum	Maximum
OC3 IR 4/STM1 SH 1310	-15 dBm	-8 dBm	-28 dBm	-8 dBm
OC3IR/STM1SH 1310-8	-15 dBm	-8 dBm	-28 dBm	-8 dBm
OC12 IR/STM4 SH 1310	-15 dBm	-8 dBm	-28 dBm	-8 dBm
OC12 LR/STM4 LH 1310	-3 dBm	+2 dBm	-28 dBm	-8 dBm
OC12 LR/STM4 LH 1550	-3 dBm	+2 dBm	-28 dBm	-8 dBm
OC12 IR/STM4 SH 1310-4	-15 dBm	-8 dBm	-30 dBm	-8 dBm
OC48 IR/STM16 SH AS 1310	-5 dBm	0 dBm	-18 dBm	0 dBm
OC48 LR/STM16 LH AS 1550	-2 dBm	+3 dBm	-28 dBm	-8 dBm
OC48 ELR/STM16 EH 100 GHz	-2 dBm	0 dBm	-27 dBm at 1E-12 BER	-9 dBm
OC192 SR/STM64 IO 1310	-6 dBm	-1 dBm	-11 dBm	-1 dBm
OC192 IR/STM64 SH 1550	-1 dBm	+2 dBm	-14 dBm	-1 dBm
OC192 LR/STM64 LH 1550	+7 dBm	+10 dBm	-19 dBm	-10 dBm
OC192 LR/STM64 LH ITU 15xx.xx	+3 dBm	+6 dBm	-22 dBm	-9 dBm
15454_MRC-12 ¹ (ONS-SI-2G-S1)	-10 dBm	-3 dBm	-18 dBm	-3 dBm
15454_MRC-12 ¹ (ONS-SI-2G-I1)	-5 dBm	0 dBm	-18 dBm	0 dBm
15454_MRC-12 ¹ (ONS-SI-2G-L1)	-2 dBm	3 dBm	-27 dBm	-9 dBm
15454_MRC-12 ¹ (ONS-SI-2G-L2)	-2 dBm	3 dBm	-28 dBm	-9 dBm
15454_MRC-12 ¹ (ONS-SC-2G-30.3 through ONS-SC-2G-60.6)	0 dBm	4 dBm	-28 dBm	-9 dBm
15454_MRC-12 ¹ (ONS-SI-622-I1)	-15 dBm	-8 dBm	-28 dBm	-8 dBm
15454_MRC-12 ¹ (ONS-SI-622-L1)	-3 dBm	2 dBm	-28 dBm	-8 dBm
15454_MRC-12 ¹ (ONS-SI-622-L2)	-3 dBm	2 dBm	-28 dBm	-8 dBm
15454_MRC-12 ¹ (ONS-SE-622-1470 through ONS-SE-622-1610)	0 dBm	5 dBm	-28 dBm	-3 dBm
15454_MRC-12 ¹ (ONS-SI-155-I1)	-15 dBm	-8 dBm	-30 dBm	-8 dBm
15454_MRC-12 ¹ (ONS-SI-155-L1)	-5 dBm	0 dBm	-34 dBm	-10 dBm
15454_MRC-12 ¹ (ONS-SI-155-L2)	-5 dBm	0 dBm	-34 dBm	-10 dBm
15454_MRC-12 ¹ (ONS-SE-155-1470 through ONS-SE-155-1610)	0 dBm	5 dBm	-34 dBm	-3 dBm
15454_MRC_12 ¹ ONS-SI-155-I1-MM=	-9 dBm	-14 dBm	-14 dBm	-5 dBm
15454_MRC_12 ¹ ONS-SI-622-I1-MM=	-9 dBm	-14 dBm	-14 dBm	-5 dBm
15454_MRC_12 ¹ ONS-SC-Z3-1470 through ONS-SC-Z3-1610	0 dBm	5 dBm	-9 dBm	+5 dBm
15454_MRC_12 ¹ ONS-SE-Z1=	-5 dBm	0 dBm	-10 dBm 0 dBm -18 dBm 0 dBm	-23 dBm (OC-3) -23 dBm (OC-12) 0 dBm

Table 2-4: Optical Card Transmit and Receive Levels

			0 dBm	(OC-48) -21 dBm (FC) -22 dBm (GE)
OC192SR1/STM64IO Short Reach ² (ONS-XC-10G-S1)	-6 dBm	-1 dBm	-11 dBm	-1 dBm
OC192/STM64 Any Reach ² (ONS-XC-10G-S1)	-6 dBm	-1 dBm	-11 dBm	-1 dBm
OC192/STM64 Any Reach ² (ONS-XC-10G-I2)	-1 dBm	2 dBm	-14 dBm	2 dBm
OC192/STM64 Any Reach ² (ONS-XC-10G-L2)	0 dBm	4 dBm	-24 dBm	-7dBm

1. Designated as MRC-12 in CTC

2. Designated as STM64-XFP in CTC

2. Inspect and clean all fiber connectors thoroughly. See the [NTP-D112 Clean Fiber Connectors](#) for instructions. Dust particles can degrade performance. Put caps on any fiber connectors that are not used.
3. As needed, complete the ["DLP-D42 Install Fiber-Optic Cables on an LGX Interface"](#) task.
4. As needed, complete the ["DLP-D22 Install Fiber-Optic Cables in a 1+1 Configuration"](#) task.
5. As needed, complete the ["DLP-D337 Install Fiber-Optic Cables for SNCP Configurations"](#) task.
6. As needed, complete the ["DLP-D338 Install Fiber-Optic Cables for MS-SPRing Configurations"](#) task.
7. Continue with the [NTP-D245 Route Fiber-Optic Cables](#).

Stop. You have completed this procedure.

NTP-D245 Route Fiber-Optic Cables

Purpose	This procedure routes fiber-optic cables.
Tools/Equipment	None
Prerequisite Procedures	NTP-D19 Install Fiber-Optic Cables on Optical Cards NTP-D286 Install the FC MR-4 Cards
Required/As Needed	As needed
Onsite/Remote	Onsite
Security Level	None

1. As needed, complete the ["DLP-D45 Install the Fiber Boot"](#) task. Fiber boots are required for all STM-N cards except the STM-64, OC192SR1/STM64IO Short Reach, OC192/STM64 Any Reach (STM64-XFP), and STM-16 AS cards.
2. Open the fold-down front door on the cable-management tray ([Figure 2-2](#)).

Figure 2-2: Fold-Down Front Door of the Cable-Management Tray

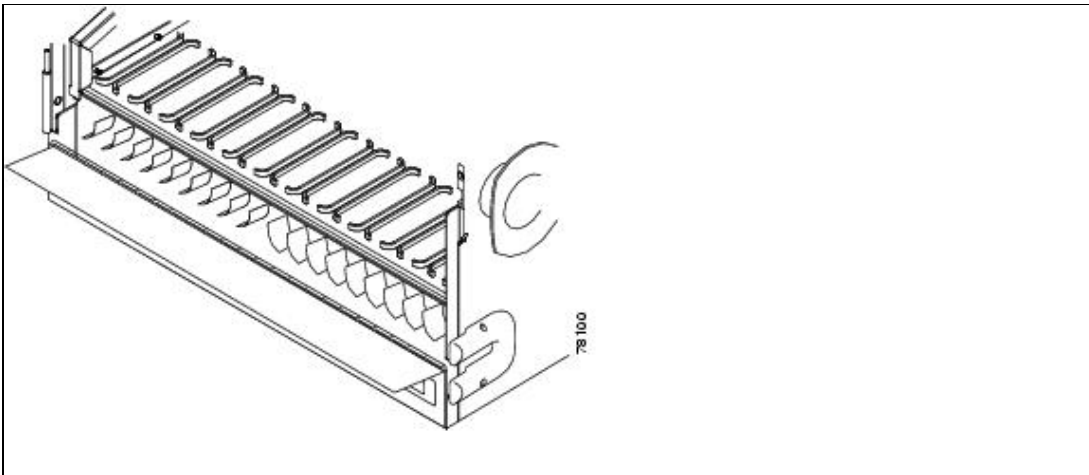

3. Route the fiber cable on the card faceplate through the fiber clip on the faceplate ([Figure 2-3](#)). Fiber clips are factory-attached to the faceplate of the STM-N cards.
4. If you installed a 15454_MRC-12 card, complete the "[DLP-D104 Install the Fiber Clip on MRC Cards](#)" task. The 15454_MRC-12 cards are shipped with two versions of a fiber clip that plug into the faceplate. The clip must be selected according to the cabinet door depth. Use the short clip with the standard door and the long clip with the extended door.

GBICs, SFPs, and XFPs do not have fiber clips; therefore, if you are routing optical cable from an FC_MR-4, E1000-2-G, G1K-4, ML1000-2, or STM64-XFP cards, skip to Step 5.

Figure 2-3: Routing Fiber-Optic Cables on the Optical-Card Faceplate

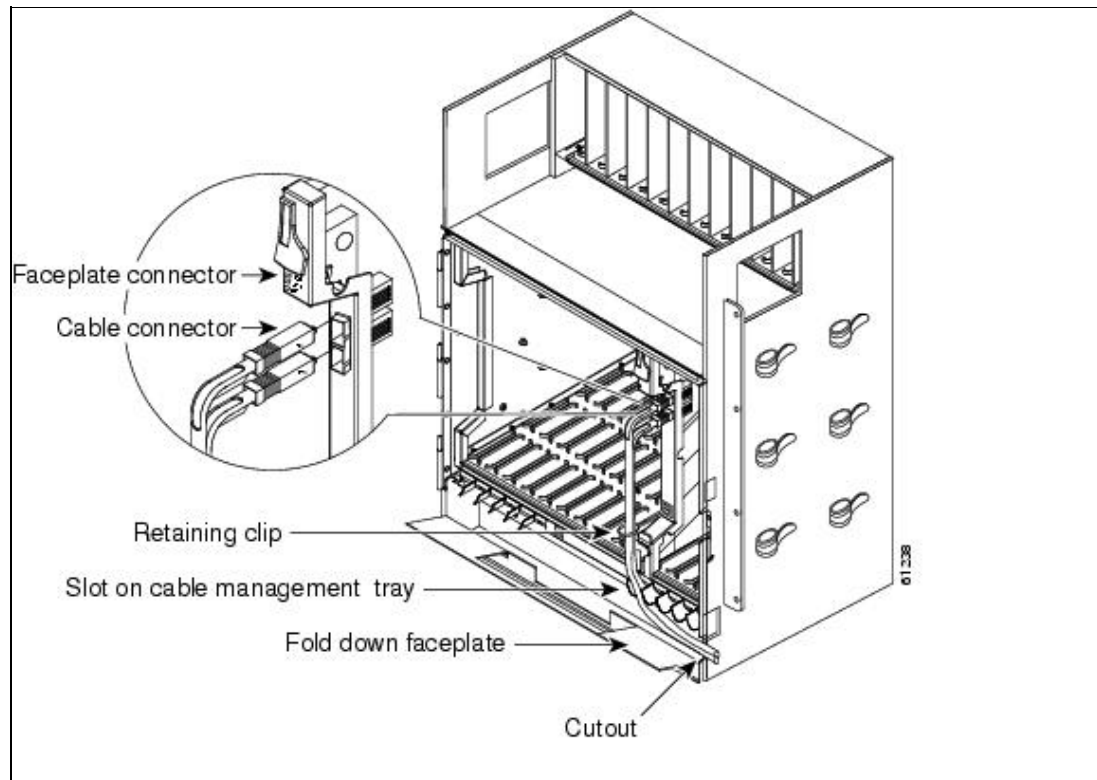

5. Route the fiber cables into the cable-management tray ([Figure 2-3](#)).
6. Route the fiber cables out either side of the cable-management tray through the cutouts on each side of the shelf assembly. Use the reversible fiber guides to route cables out the desired side.

7. Close the fold-down front door when all fiber cables in the front compartment are properly routed.

Stop. You have completed this procedure.

NTP-D227 Remove and Replace a Card

Purpose	This procedure removes and replaces cards in the ONS 15454 SDH shelf.
Tools/Equipment	None
Prerequisite Procedures	DLP-D60 Log into CTC
Required/As Needed	As needed
Onsite/Remote	Onsite
Security Level	Provisioning or higher

1. If you are not logged into CTC and you need to remove a card, remove the card as described in Step 3. When you log into CTC, troubleshoot the mismatched equipment alarm (MEA) using the *Cisco ONS 15454 SDH Troubleshooting Guide*.
2. If you are logged into CTC, complete one of the following:
 - ◆ Complete the "[DLP-D191 Delete a Card](#)" task and continue with Step 3.
 - ◆ Complete the "[DLP-D247 Change an STM-N Card](#)" task to delete a card and replace it with a different optical card while maintaining existing provisioning.
3. Physically remove the card:
 1. Open the card latches/ejectors.
 2. Use the latches/ejectors to pull the card forward and away from the shelf.
4. Insert the new card using one of the following procedures as applicable:
 - ◆ [NTP-D15 Install the Common Control Cards](#)
 - ◆ [NTP-D16 Install STM-N Cards and Connectors](#)
 - ◆ [NTP-D17 Install the Electrical Cards](#)
 - ◆ [NTP-D18 Install Ethernet Cards and Connectors](#)
 - ◆ [NTP-D286 Install the FC MR-4 Cards](#)
5. As needed, continue with the [NTP-D19 Install Fiber-Optic Cables on Optical Cards](#).

Stop. You have completed this procedure.

NTP-D20 Replace the Front Door

Purpose	This procedure replaces the front door and door ground strap after installing cards and fiber-optic cables.
Tools/Equipment	Pinned hex key
Prerequisite Procedures	NTP-D3 Open and Remove the Front Door
Required/As Needed	Required
Onsite/Remote	Onsite
Security Level	None

Note: Be careful not to crimp any fiber cables that are connected to the STM-N cards or DWDM cards. Some might not have the fiber boot attached.

1. Insert the front door into the hinges on the shelf assembly.
2. Attach the pluggable ground wire ([Figure 2-4](#)).

Figure 2-4: ONS 15454 SDH Front Door with Hinges and Ground Wire

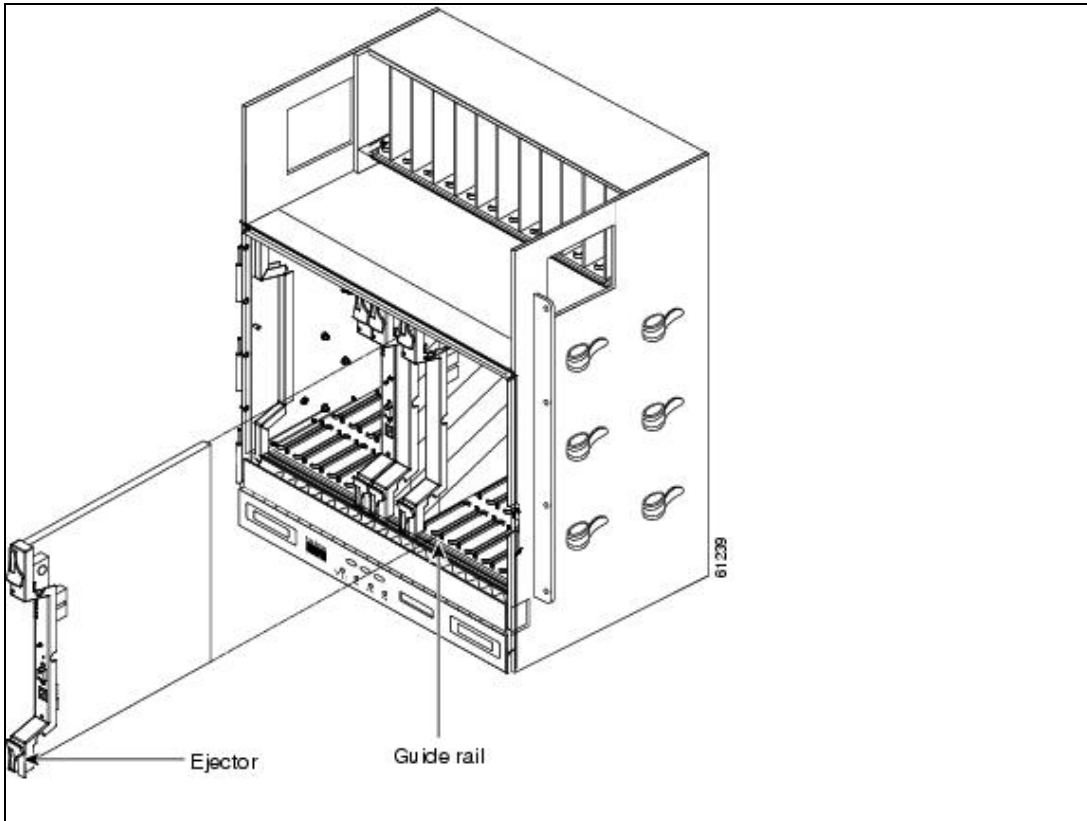

3. Swing the door closed.

Note: The ONS 15454 SDH comes with a pinned hex key tool for locking and unlocking the front door. Turn the key counterclockwise to unlock the door and clockwise to lock it.

Stop. You have completed this procedure.