

This page gives complete instructions for installing and configuring the **simplest deployment** of Cisco Unified MeetingPlace Video Integration.

Contents

- 1 Requirements for This Configuration
 - ◆ 1.1 General
 - ◆ 1.2 Network
 - ◆ 1.3 Cisco Unified MeetingPlace System
 - ◆ 1.4 MCU
 - ◆ 1.5 Video Endpoints
 - ◆ 1.6 The Video Administration Component (Installed During This Process)
 - ◆ 1.7 Other Requirements
- 2 Overview of Components
- 3 How To Prepare for Install
 - ◆ 3.1 How To Verify Preparedness of Component Systems
 - ◇ 3.1.1 Meeting the Requirements for This Configuration
 - ◇ 3.1.2 Verifying That Your Cisco Unified MeetingPlace System Works Without Video
 - 3.1.2.1 Procedure
 - ◇ 3.1.3 Verifying That the MCU Can Run Video Conferences Independently of Cisco Unified MeetingPlace
 - 3.1.3.1 Procedure
 - ◆ 3.2 Configuring the MCU
 - ◇ 3.2.1 Procedure
 - ◆ 3.3 Verifying Correct EMP Port Addressing (for 3545 MCUs only)
 - ◇ 3.3.1 Procedure
 - ◆ 3.4 Configuring the Audio Server
 - ◇ 3.4.1 Procedure
 - ◆ 3.5 Configuring the Cisco IOS Gatekeeper
 - ◇ 3.5.1 Procedure
- 4 How To Install and Configure the Video Administration Component
 - ◆ 4.1 Preparing the MCS Server for Installation
 - ◇ 4.1.1 Before You Begin
 - ◇ 4.1.2 Procedure
 - ◆ 4.2 Installing the MSDE Software
 - ◇ 4.2.1 Before You Begin
 - ◇ 4.2.2 Procedure
 - ◆ 4.3 Installing the Video Administration Component
 - ◇ 4.3.1 Before You Begin
 - ◇ 4.3.2 Procedure
 - ◆ 4.4 Accessing the Video Administration Component
 - ◇ 4.4.1 Procedure
 - ◆ 4.5 Adding the Cisco IOS Gatekeeper to the Video Administration Component

- ◊ [4.5.1 Procedure](#)
- ◆ [4.6 Identifying Your MCU in the Video Administration Component](#)
 - ◊ [4.6.1 Procedure](#)
- ◆ [4.7 Downloading Meeting Types From Your MCU](#)
 - ◊ [4.7.1 Procedure](#)
- [5 Installing the Video Integration Component](#)
 - ◆ [5.1 Before You Begin](#)
 - ◆ [5.2 Procedure](#)
- [6 How To Modify the Web Conferencing Server Configuration](#)
 - ◆ [6.1 Configuring the Web Conferencing Servers to Synchronize with the Network Time Protocol Server](#)
 - ◊ [6.1.1 Procedure](#)
 - ◆ [6.2 Uploading the Meeting Types to the Cisco Unified MeetingPlace Servers](#)
 - ◊ [6.2.1 Procedure](#)
- [7 How To Configure Cisco Unified Communications Manager](#)
 - ◆ [7.1 Adding the Cisco IOS Gatekeeper](#)
 - ◊ [7.1.1 Procedure](#)
 - ◆ [7.2 Creating an H.225 Trunk for the IOS Gatekeeper](#)
 - ◊ [7.2.1 Procedure](#)
 - ◆ [7.3 Adding A Route Pattern to Route Calls to the Internal ECS Gatekeeper](#)
 - ◊ [7.3.1 Procedure](#)
- [8 Getting More Information](#)

Requirements for *This* Configuration

This document provides instructions for installing and configuring the simplest possible deployment of Cisco Unified MeetingPlace Video Integration.

Note: Other configurations are supported but not documented here.

For *this* installation, these instructions assume your environment meets the following conditions:

General

Caution! If you have already attempted this installation, uninstall everything and undo changes you have made before reinstalling following these instructions.

- You have not yet begun to install and configure this application.
- Your equipment meets the requirements described in the [System Requirements](#) and [Compatibility Matrix](#) pages.
- Your equipment complies with the limitations, restrictions, and other information in the *Release Notes for Cisco Unified MeetingPlace Video Integration*, available from http://www.cisco.com/en/US/products/sw/ps5664/ps5669/prod_release_notes_list.html.
- The following restrictions apply for the configuration described in this document only. They do not necessarily apply to all deployments.

Network

- There is a single Cisco Unified Communications Manager or Cisco Unified CallManager that is set up and can route calls properly.
- There is a single Cisco IOS Gatekeeper (plus one internal ECS gatekeeper that is installed with this application).
- All components are installed at the same geographic location and are on the same network.
- There are no bandwidth bottlenecks between devices on your network.
- *This* deployment needs to support only IP resources, no ISDN or PSTN resources.
- You have a Network Time Protocol (NTP) server to which you can synchronize all servers in this deployment.

Cisco Unified MeetingPlace System

- The Cisco Unified MeetingPlace system (release 6.1) has only one audio server.
- The Cisco Unified MeetingPlace system is licensed for video conferencing.
- The web conferencing servers are not configured for DMZ access.
- The Microsoft Outlook and Lotus Notes integrations are not used.
- Calls are routed via a Cisco Unified MeetingPlace H.323/SIP IP Gateway.
- The audio system includes only IP phones.

MCU

- One Cisco Unified Videoconferencing Multipoint Control Unit (MCU), model 3515 or 3545, release 5.x.

Video Endpoints

- All video endpoints are H.323 endpoints or desktop cameras associated with the primary phone number configured for each user in Cisco Unified MeetingPlace.
- There are no high-definition endpoints.

The Video Administration Component (Installed During This Process)

- Video Administration will control only video conferences. Audio-only conferences are handled by the audio server.
- You have a clean, dedicated Cisco Media Convergence Server (MCS) server model 7835 or 7845 available on which to install the Video Administration component. This server is on your network and has a static IP address.
- Your environment has no limitations or restrictions that will prevent you from using the default settings for this application, including the default database provided with this software.

Other Requirements

This document assumes you are familiar with administrative functions for the following products:

- Cisco Unified MeetingPlace audio and web conferencing
- Cisco Unified Videoconferencing
- Cisco Unified Communications Manager or Cisco Unified CallManager

Overview of Components

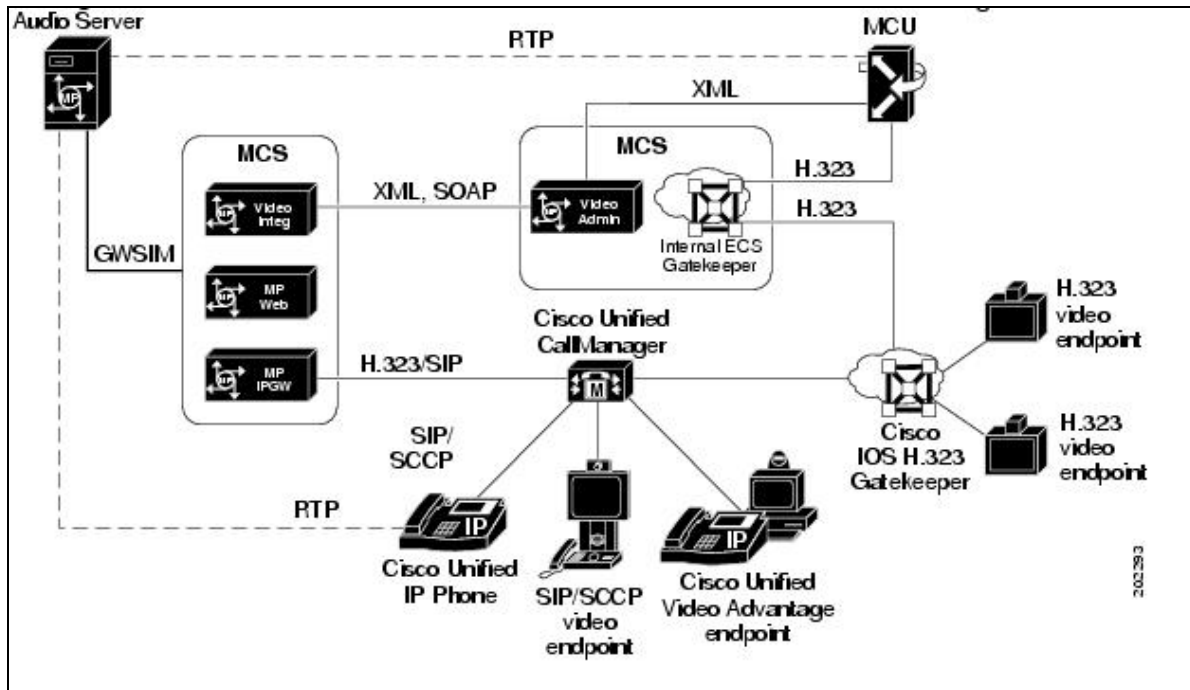

How To Prepare for Install

Important: Perform all tasks in this document in the order they appear, exactly as described. You can configure additional changes after you have verified that your system is running properly.

- [How To Verify Preparedness of Component Systems](#)
- [Configuring the MCU](#)
- [Verifying Correct EMP Port Addressing \(for 3545 MCUs only\)](#)
- [Configuring the Audio Server](#)
- [Configuring the Cisco IOS Gatekeeper](#)

How To Verify Preparedness of Component Systems

- [Meeting the Requirements for This Configuration](#)
- [Verifying That Your Cisco Unified MeetingPlace System Works Without Video](#)
- [Verifying That the MCU Can Run Video Conferences Independently of Cisco Unified MeetingPlace](#)

Meeting the Requirements for *This* Configuration

Make sure your equipment, software and network characteristics meet the requirements for the configuration detailed in *this* document. See [Requirements for This Configuration](#).

Verifying That Your Cisco Unified MeetingPlace System Works Without Video

Procedure

1. Make sure audio participants can dial in to join a conference.
2. Make sure the system can dial out to audio participants to bring them into the conference.
3. Make sure all participants can successfully hear each other and participate in the same web conference.

Verifying That the MCU Can Run Video Conferences Independently of Cisco Unified MeetingPlace

Procedure

1. Schedule a video conference on the MCU.
2. Make sure video endpoints can dial in to join a video conference.
3. Make sure the MCU can dial out to video endpoints to bring them into the conference.
4. Make sure all video endpoints can see and hear each other in the video conference.

Configuring the MCU

Procedure

1. Log in to your MCU Administrator interface.
2. Synchronize the MCU with the NTP server:
 1. For Model 3515 MCU: Click **Device**.
For Model 3545 MCU: Click **Board**.
 2. Click the **Basics** tab.
 3. For Date/Time, click **Change**.
 4. Check **NTP Enabled**.
 5. Click **Synchronize with NTP server address**.
 6. Enter the IP address of the NTP server.
 7. Click **Upload**.
3. Check to be sure the port addressing is correct:
 1. Click the **Addressing** tab.
 2. Make sure **Port status** is set to **100Mbps/ Full Duplex**.
 3. Check to see which port on the switch the MCU is physically connected to.
 4. Set that port to **100Mbps/ Full Duplex**.
 5. Click **Upload**.
4. Click **MCU**.
5. Click the **Settings** tab.
6. Click **Advanced**.
7. Set options:

Option	Value
Conferences Can Be Created Using	Scheduler only. After you change this setting, it will only be possible to create video conferences via Cisco Unified MeetingPlace.
Participants Can Join the Conference Using	Invite and Dial-in
External conference authorization policy	None

8. Click **Upload**.

9. Click the **Protocols** tab.

10. Click **H.323**.

11. Set **Gatekeeper Address** to the IP Address of the MCS server on which you will install the Video Administration component.

12. Click **Upload**.

13. If the preconfigured MeetingPlace service prefix will not work with your existing dial plan:

1. Click the **Services** tab.
2. Change the prefix to a number that will work in your dial plan.
3. Click **Upload**.

Verifying Correct EMP Port Addressing (for 3545 MCUs only)

Procedure

1. Make sure the port addressing for the EMP card is set to **Auto-negotiate**.
2. Make sure the port to which the EMP card is physically connected is also set to **Auto-negotiate**.
3. If either of these is not correct, see the documentation for your EMP card.

Configuring the Audio Server

Procedure

1. Log in to Cisco Unified MeetingPlace MeetingTime.
2. Synchronize the audio server with the NTP server:
 1. Click the **Configure** tab.
 2. Click **System Parameters** in the left panel.
 3. Click **Query**.
 4. Look for **NTP Server** in the panel on the right.
 5. Enter the IP address of your NTP server.
 6. Click **Save changes**.

3. Configure user and group profiles for video conferencing, especially the **Allow Video Scheduling** parameter in the **Restrictions** section.
4. Set Video Meeting parameters:
 1. Click the **Configure** tab.
 2. Click **Scheduling Parameters** in the left panel.
 3. Click **Query**.
 4. Scroll down in the panel on the right to **Video Meetings**.
 5. Make sure that **Max ports per meeting** does not exceed the total number of ports available on your MCU.
 6. Leave the other values at the default for this configuration.
 7. Click **Save changes**, if applicable.

Configuring the Cisco IOS Gatekeeper

The Cisco IOS Gatekeeper must:

- route calls from H.323 endpoints that begin with the MeetingPlace service prefix to the internal ECS gatekeeper that is included in the Video Administration component of Cisco Unified MeetingPlace Video Integration.
- route calls to the H.323 endpoints.
- route unknown calls to Cisco Unified Communications Manager.

Procedure

1. Access the Cisco IOS Gatekeeper.
2. Make sure your configuration includes the following entries: (replace the variables between the angle brackets as appropriate)

```
zone local <LOCAL_ZONE_NAME><DOMAIN> <LOCAL_ACTIVE_IP_ADDRESS
FOR_GATEKEEPER_REGISTRATION>
zone remote <VIDEO_ADMINISTRATION_ZONE_NAME> <DOMAIN> <IP
ADDRESS_OF_THE_SERVER_ON_WHICH_YOU_WILL_INSTALL_THE_VIDEO
ADMINISTRATION_COMPONENT>
zone prefix <VIDEO_ADMINISTRATION_ZONE_NAME> <MEETINGPLACE
SERVICE_PREFIX_ON_MCU*>
zone prefix <LOCAL_ZONE_NAME><PATTERN_TO_COVER_VIDEO_ENDPOINT
DEVICES_REGISTERED_TO_THIS_GATEKEEPER>
gw-type-prefix <DEFAULT_TECHNOLOGY_PREFIX_AS_CONFIGURED_IN
CISCO_UNIFIED_COMMUNICATIONS_MANAGER> default-technology
lrq forward-queries add-hop-count
no use-proxy <LOCAL_ZONE_NAME> default inbound-to terminal
no use-proxy <LOCAL_ZONE_NAME> default outbound-from terminal
```

Note: The port number 1719 is appended automatically to the zone remote line.

How To Install and Configure the Video Administration Component

The Video Administration component includes an internal ECS Gatekeeper that routes calls between the Video Administration component and the MCU.

Note: All H.323 endpoints and Cisco Unified Communications Manager trunks register to the external Cisco IOS Gatekeeper, which routes all calls between the internal gatekeeper and the video endpoints.

- [Preparing the MCS Server for Installation](#)
- [Installing the MSDE Software](#)
- [Installing the Video Administration Component](#)
- [Accessing the Video Administration Component](#)
- [Adding the Cisco IOS Gatekeeper to the Video Administration Component](#)
- [Identifying Your MCU in the Video Administration Component](#)
- [Downloading Meeting Types From Your MCU](#)

Preparing the MCS Server for Installation

Before You Begin

Make sure that the Microsoft Windows SNMP service is installed.

Procedure

On the MCS server on which you will install the Video Administration component:

1. Configure this server to synchronize with the NTP server:
 1. At the command line, issue **net time /setsntp:<NTP-SERVER-NAME>**
 2. Set the Windows Time service (in the Services Control Panel) to start automatically, then start the service.
2. Make sure the following ports are not occupied:
 - ◆ 1098
 - ◆ 1099

Installing the MSDE Software

Install Microsoft SQL Server Desktop Engine (MSDE) on the same MCS server as the Video Administration component.

Before You Begin

Make sure you will not need to interrupt this installation.

Procedure

1. Launch **Setup_MSDE.exe**.
2. Accept all defaults.

Note: The actual database will be created during installation of the Video Administration component.

Installing the Video Administration Component

Before You Begin

- Make sure you install this component on the server on which you have just installed MSDE.
- Make sure you have completed all previous tasks in this document.
- Make sure you will not need to interrupt this installation.

Procedure

1. Run the Video Administration installer.
The name of the installer should be similar to **Cisco_Video_Admin_<version #>.exe** or **CUMP_Video_Administration <version number>.exe**.
2. Accept all defaults when presented.
Exception: You may change the database password for security purposes.
Note your new password if you change it.
3. When prompted for the **Video Admin Account Login Information**, enter values of your choice.
(This is the only set of login information that does not present default values.)
You will use this information to access the Video Administration component.
Restrictions:

Value	Restriction
Login ID	No more than 16 characters long
Password	No more than 12 characters long

Accessing the Video Administration Component

The Video Administration component runs as a Windows service. This service automatically starts when the server on which it is installed starts.

Procedure

1. Point your browser at **http://<Your-Video-Administration-server>:8080/va** .
Note: Port number is required.
2. If you see a window that offers options for **User Provisioning**:
 1. Make no changes.
 2. Click **OK**.
 3. Click **OK** again.

You will see this only the first time you access Video Administration after installation.
3. Log in.

Adding the Cisco IOS Gatekeeper to the Video Administration Component

Procedure

1. Click **Resource Management**.
2. Click the **Gatekeeper/SIP Server** tab.
Note: The local_gatekeeper that you see in the list is the internal ECS gatekeeper.
 The authorization connection will show **Disconnected**. This is expected.
3. Click **Add**.
4. Add your Cisco IOS Gatekeeper:

Option	Value
Name	Identifying name for your Cisco IOS Gatekeeper
IP Address	IP address of your Cisco IOS Gatekeeper
Model	Cisco MCM 500
All other values	Use the defaults.

5. Click **OK**.

This gatekeeper is automatically defined as the neighbor of the internal ECS gatekeeper. The Cisco IOS Gatekeeper does not necessarily show Connected when you view it in the table.

Identifying Your MCU in the Video Administration Component

Procedure

1. Click **Resource Management**.
2. Click the **MCU** tab.
3. Click **Add**.
4. Add information about your MCU:

Option	Value
Name	Name of your MCU
IP Address	IP Address of MCU

Model	Cisco IPVC - 36xx v5.x
Registered To	local_gatekeeper
Login Name	Login information for the MCU.
Login Password	Login information for the MCU.
All other values	Use the defaults.

5. Click **OK**.

6. If you have configured SNMP on your MCU, configure the Video Administration server to match:

1. Click **Advanced**.
2. Enter the values to match those configured on your MCU.
3. Click **OK**.

7. Click **OK**. 8. Wait for the Video Administration component to synchronize with the MCU.

Downloading Meeting Types From Your MCU

Note: Meeting Types in the Video Administration component are called Services or Service Prefixes in the MCU.

Procedure

1. Click **Meeting Types**.
2. Click **Download**.
You should see the MeetingPlace service in the list.
3. Click **OK**.
4. Click **OK**.

Installing the Video Integration Component

Before You Begin

- Make sure you have completed all previous tasks in this document.
- Make sure that the Cisco Unified MeetingPlace system is not in use. The Video Integration installer will stop the web conferencing master service and all subordinate services.
- Verify that the Video Administration server and the Cisco Unified Videoconferencing MCUs are available on the network (reachable via their IP addresses).
- Note the E.164 number that is used to direct calls to the Cisco Unified MeetingPlace H.323/SIP IP Gateway. To locate that number:

On the machine on which the Cisco Unified MeetingPlace H.323/SIP IP Gateway is installed, choose **Start > Programs > MeetingPlace Applications > MeetingPlace Management**.

Procedure

1. Run the **Setup.exe** for Cisco Unified MeetingPlace Video Integration.
After installation is complete, Cisco Unified MeetingPlace services will restart automatically.
2. Repeat Step 1 on each web conferencing server. Check the **Host Video Conferences** check box for only one web conferencing server.

How To Modify the Web Conferencing Server Configuration

- Configuring the Web Conferencing Servers to Synchronize with the Network Time Protocol Server
- Uploading the Meeting Types to the Cisco Unified MeetingPlace Servers

Configuring the Web Conferencing Servers to Synchronize with the Network Time Protocol Server

For a Release 5.4 Cisco Unified MeetingPlace system, use this procedure.

For a Release 6.0 system, the web conferencing servers automatically synchronize with the audio server.

Procedure

1. Navigate to the Windows Control Panel.
2. Double-click **MeetingPlace Gateways**.
3. Click **Internet Time**.
4. Check **Synchronize Server Time with NTP Server**.
5. Enter values for all other options in the window.
6. Click **OK**.
7. Repeat this procedure on each web conferencing server.

Uploading the Meeting Types to the Cisco Unified MeetingPlace Servers

This procedure imports the Meeting Types from the Video Administration component into the Cisco Unified MeetingPlace system.

Procedure

1. Sign in to any Cisco Unified MeetingPlace Web Conferencing server in the system.
2. Click **Admin**.
3. Click **Replication Service**.
4. For **Replication Service Command**, choose **Update All Terminals**.

This also updates the Meeting Types.

5. Click **Submit**.

How To Configure Cisco Unified Communications Manager

Information in this section also applies to your supported version of Cisco Unified CallManager.

Do the following if you have not yet done so:

- [Adding the Cisco IOS Gatekeeper](#)
- [Creating an H.225 Trunk for the IOS Gatekeeper](#)
- [Adding A Route Pattern to Route Calls to the Internal ECS Gatekeeper](#)

Adding the Cisco IOS Gatekeeper

Procedure

1. Launch and log in to the Cisco Unified Communications Manager Administration interface.
2. Choose **Device > Gatekeeper**.
3. Click **Add a New Gatekeeper** or **Add New**.
The exact text depends on the Cisco Unified Communications Manager version.
4. Enter options:

Option	Value
Host Name / IP Address	IP address of the IOS gatekeeper.
Description	A name that identifies this gatekeeper.
Enable Device	Check the check box.
Other options	Values as appropriate for your environment.

5. Click **Insert** or **Save**.

The exact text depends on the Cisco Unified Communications Manager version.

Creating an H.225 Trunk for the IOS Gatekeeper

Procedure

1. Choose **Device > Trunk** from the Cisco Unified Communications Manager Administration menu bar.
2. Click **Add a New Trunk** or **Add New**.

The exact text depends on the Cisco Unified Communications Manager version.

3. For Trunk Type, choose **H.225 (Gatekeeper Controlled)**.
4. Click **Next**.
5. Enter options. (Scroll down to see all options.)

Option	Value
Device Name	A name that identifies this trunk.
Description	A descriptive name for this trunk that connects to your IOS gatekeeper.
Retry Video Call as Audio	Check the check box.
Wait for Far End H.245 Terminal Capability Set	Uncheck the check box.
Gatekeeper Name	Select the Cisco IOS Gatekeeper that you configured earlier in this process.
Terminal Type	Gateway.
Technology Prefix	The prefix or pattern that will route calls to Cisco Unified Communications Manager from the gatekeeper. This value must match the default technology prefix specified in the IOS Gatekeeper.
Zone	Enter the name of the local zone you specified in Configuring the Cisco IOS Gatekeeper . This value is case-sensitive.
Other parameters	Values as appropriate for your environment.

6. Click **Insert** or **Save**.

The exact text depends on the Cisco Unified Communications Manager version.

7. Click **OK**.

8. Click **Reset Trunk** or **Reset**.

The exact text depends on the Cisco Unified Communications Manager version.

Adding A Route Pattern to Route Calls to the Internal ECS Gatekeeper

Procedure

1. From the Cisco Unified Communications Manager Administration menu bar, do one of the following:
 - ◆ In Cisco Unified Communications Manager 4.0, choose **Route Plan > Route Pattern/Hunt Pilot**.
 - ◆ In Cisco Unified Communications Manager 4.1, choose **Route Plan > Route / Hunt > Route Pattern**.
 - ◆ In Cisco Unified Communication Manager 5.x and 6.1, choose **Route / Hunt > Route Pattern**.
2. Click **Add a New Route Pattern/Hunt Pilot** or **Add New**.

The exact text depends on the Cisco Unified Communications Manager version.

3. Enter options:

Option	Value
Route Pattern/Hunt Pilot	The MeetingPlace service prefix you defined on the Cisco Unified Videoconferencing MCU, followed by an exclamation point (!).
Description	A name that describes this route pattern.
Cisco Unified Communications Manager 4.0: Gateway or Route/Hunt List	The IP address or hostname of the H225 Trunk (Gatekeeper Controlled) that you created.
Cisco Unified Communications Manager 4.1: Gateway or Route List	
Cisco Unified Communications Manager 5.1: Gateway/Route List	
Provide Outside Dialtone	Uncheck this check box.
Other parameters.	Values as appropriate for your environment.

4. Click **Insert** or **Save**.

The exact text depends on the Cisco Unified Communications Manager version.

5. If you see a message telling you that the authorization code will not be activated, click **OK**.

This deployment does not use authorization codes.

Getting More Information

See complete information about Cisco Unified MeetingPlace Video Integration [here](#).

The "Cisco Unified MeetingPlace Integration" chapter of the *Cisco Unified Communications SRND Based on Cisco Unified Communications Manager 6.1* has a section on "Unified MP Video Integration". This Solution Reference Network Design document is available at http://www.cisco.com/en/US/products/sw/voicesw/ps556/products_implementation_design_guides_list.html.